

DO NOT SCALE

28/10/2014

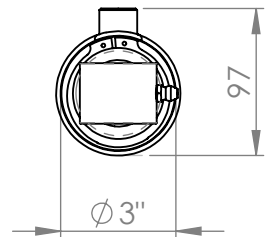
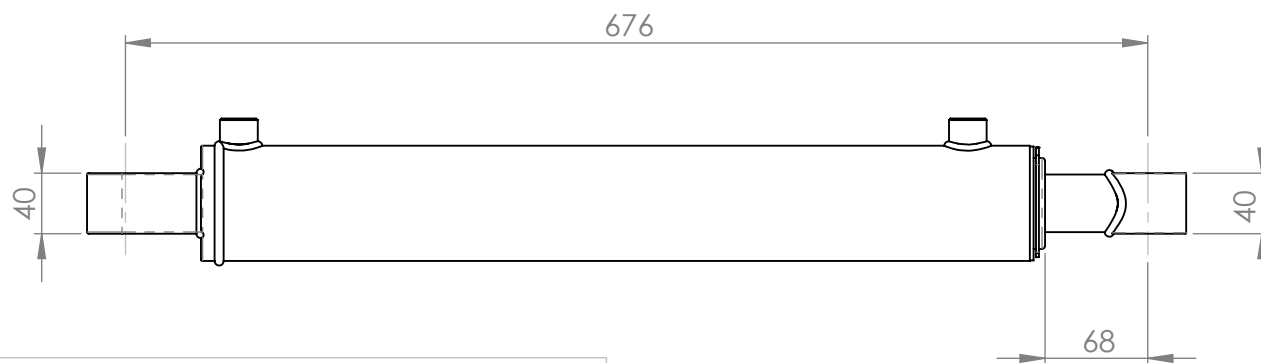
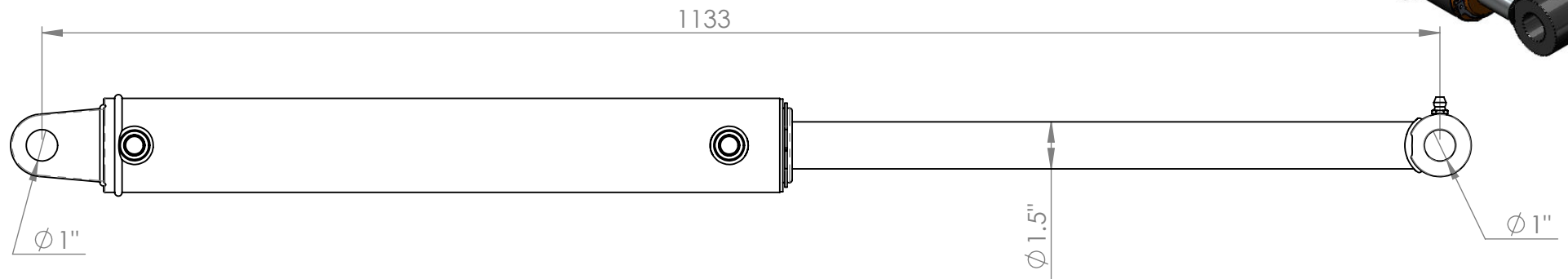
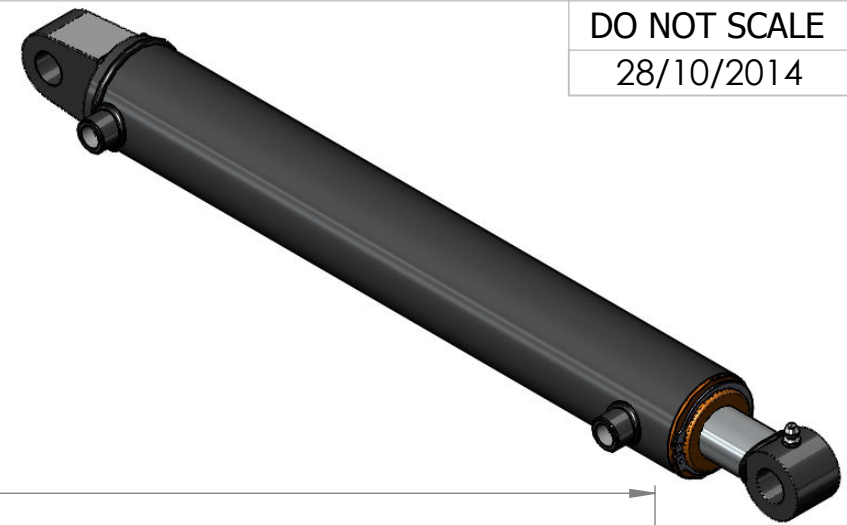

The information contained in this drawing is proprietary to MOTUS and shall not be reproduced or disclosed in whole or in part or used for any design or manufacture except when such user possesses direct written authorisation from MOTUS

Ram Phone: 0800 66 88 74  
 Phone: +64 6 879 8590  
[sales@motushydraulics.co.nz](mailto:sales@motushydraulics.co.nz)  
[www.motushydraulics.co.nz](http://www.motushydraulics.co.nz)

DESCRIPTION	PC15	FORCE RETRACT	1370kg @ 2250psi
SEAL KIT No:	SK250150	PORTS	3/8" FM BSPP
FORCE EXTENSION	3140kg @ 2250psi	BASE MOUNT	6508
STROKE	457mm	SHAFT MOUNT	6588
CLOSED CENTRES	676mm		
OPEN CENTRES	1133mm		