

DO NOT SCALE

28/10/2014

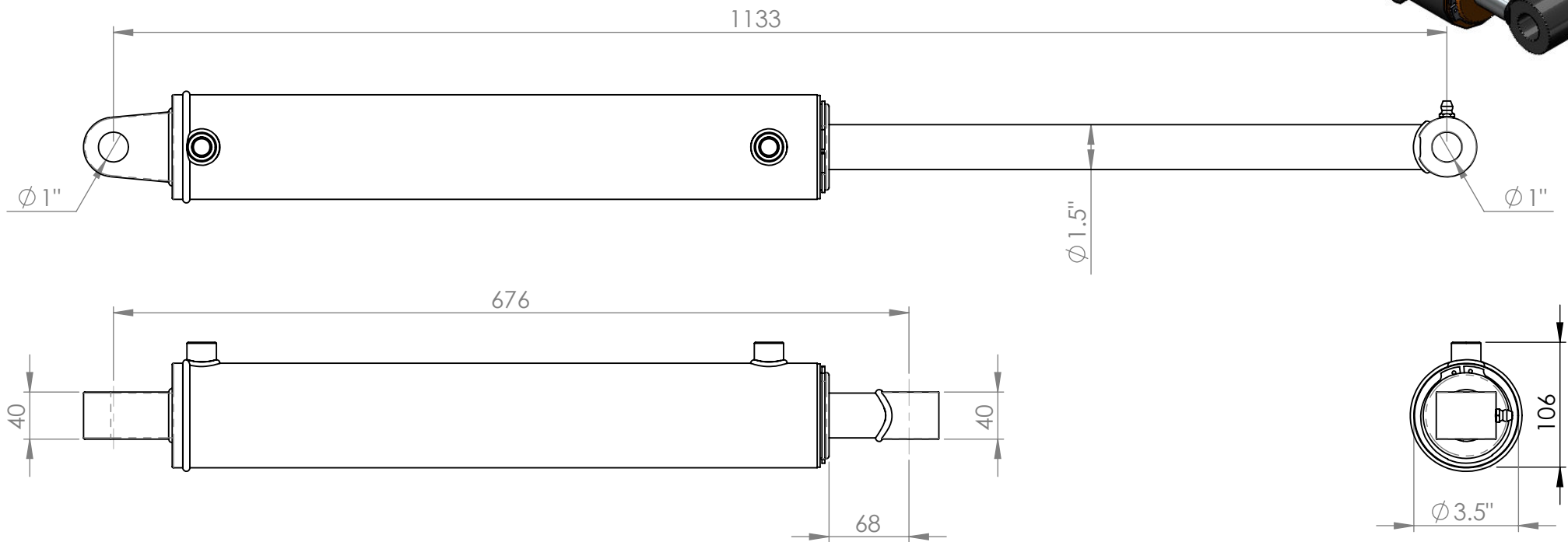
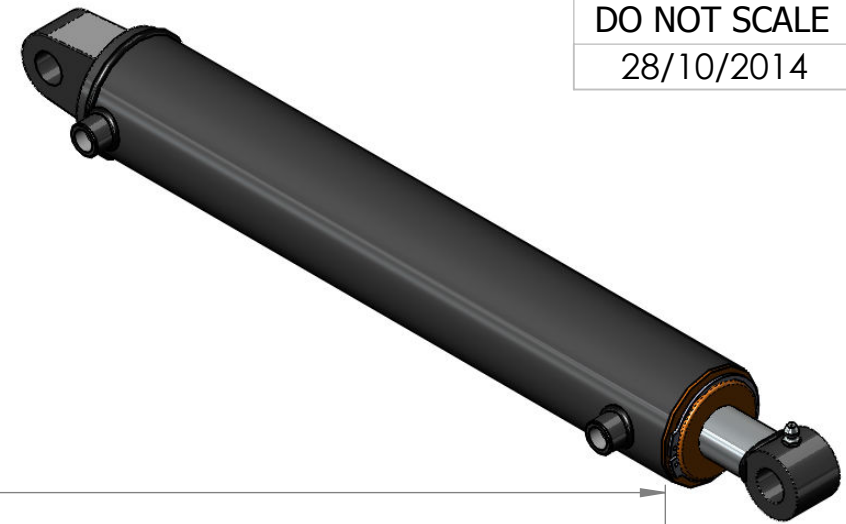

The information contained in this drawing is proprietary to MOTUS and shall not be reproduced or disclosed in whole or in part or used for any design or manufacture except when such user possesses direct written authorisation from MOTUS

Ram Phone: 0800 66 88 74
 Phone: +64 6 879 8590
 sales@motushydraulics.co.nz
 www.motushydraulics.co.nz

DESCRIPTION	PC20	FORCE RETRACT	5300kg @ 2250psi
SEAL KIT No:	SK300150	PORTS	3/8" FM BSPP
FORCE EXTENSION	7060kg @ 2250psi	BASE MOUNT	6508
STROKE	457mm	SHAFT MOUNT	6588
CLOSED CENTRES	676mm		
OPEN CENTRES	1133mm		